



TO-220 Plastic-Encapsulate Voltage Regulator

7824 Three-terminal positive voltage regulator

FEATURES

- Maximum Output current I_{OM} : 1.5 A
- Output voltage V_o : 24 V
- Continuous total dissipation
 - P_D : 2 W ($T_J = 25$)
 - 15 W ($T_C = 25$)

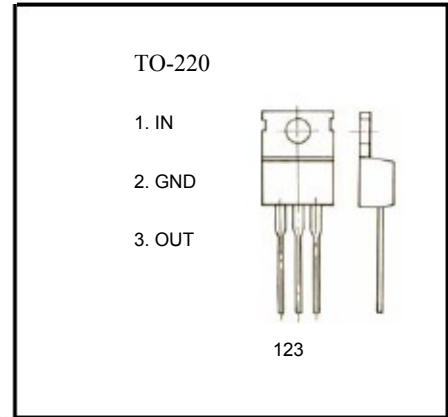

ABSOLUTE MAXIMUM RATINGS(Operating temperature range applies unless otherwise specified)

Parameter	Symbol	Value	Unit
Input Voltage	V_i	35	V
Thermal resistance junction-air	$R_{\theta JA}$	65	/W
Thermal resistance junction-cases	$R_{\theta JC}$	5	/W
Operating Junction Temperature Range	T_{OPR}	0-150	
Storage Temperature Range	T_{STG}	-65-150	

ELECTRICAL CHARACTERISTICS($V_i=27V, I_o=500mA, 0 < T_J < 125$, $C_i=0.33\mu F, C_o=0.1\mu F$, unless otherwise specified)

Parameter	Symbol	Test conditions	MIN	TYP	MAX	UNIT
Output voltage	V_o	$T_J=25$	23.6	24	24.4	V
		$21V \leq V_i \leq 33V, I_o=5mA-1A$ $P_o \leq 15W$	23.4	24	24.6	V
Load Regulation	ΔV_o	$T_J=25, I_o=5mA-1.5A$		12	360	mV
		$T_J=25, I_o=250mA-750mA$		4	180	mV
Line regulation	ΔV_o	$21V \leq V_i \leq 33V, T_J=25$		15	360	mV
		$24V \leq V_i \leq 30V, T_J=25$		5	180	mV
Quiescent Current	I_q	$T_J=25$		4.5	8	mA
Quiescent Current Change	ΔI_q	$21V \leq V_i \leq 33V$			1	mA
		$5mA \leq I_o \leq 1A$			0.5	mA
Output voltage drift	V_o / T	$I_o=5mA$		-1		mV/
Output Noise Voltage	V_N	$10Hz \leq f \leq 100KHz$		110		μV
Ripple Rejection	RR	$22V \leq V_i \leq 32V, f=120Hz, T_J=25$	53	69		dB
Dropout Voltage	V_d	$T_J=25, I_o=1A$		2		V
Output resistance	R_o	$f=1KHz$		22		$m\Omega$
Short Circuit Current	I_{sc}	$V_i=35V, T_J=25$		200		mA
Peak Current	I_{pk}	$T_J=25$		2.1		A

TYPICAL APPLICATION

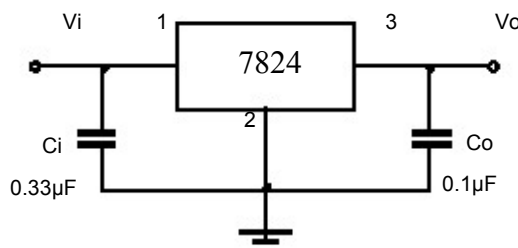

波峰焊温度曲线图(无铅) / Temperature Profile for Dip Soldering(Pb-Free)

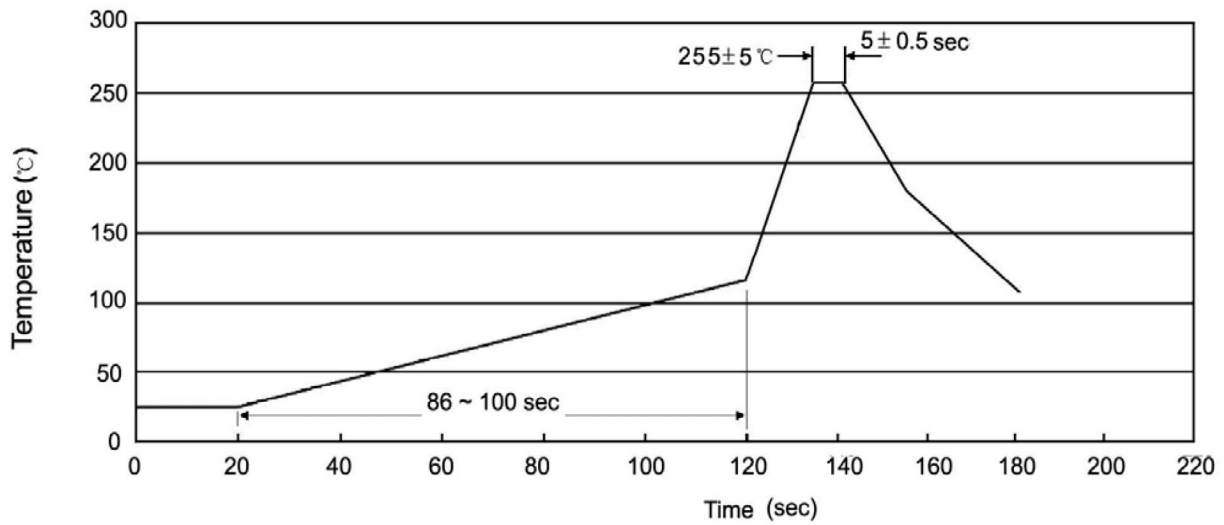

说明：

- 1、预热温度 25 ~ 150°C，时间 60 ~ 90sec;
- 2、峰值温度 255±5°C，时间持续为 5±0.5sec;
- 3、焊接制程冷却速度为 2 ~ 10°C/sec.

Note:

- 1.Preheating:25~150°C, Time:60~90sec.
- 2.Peak Temp.:255±5°C, Duration:5±0.5sec.
3. Cooling Speed: 2~10°C/sec.

耐焊接热试验条件 / Resistance to Soldering Heat Test Conditions

温度：270±5°C

时间：10±1 sec.

Temp:270±5°C

Time:10±1 sec

TO-220-3L Package Outline Dimensions

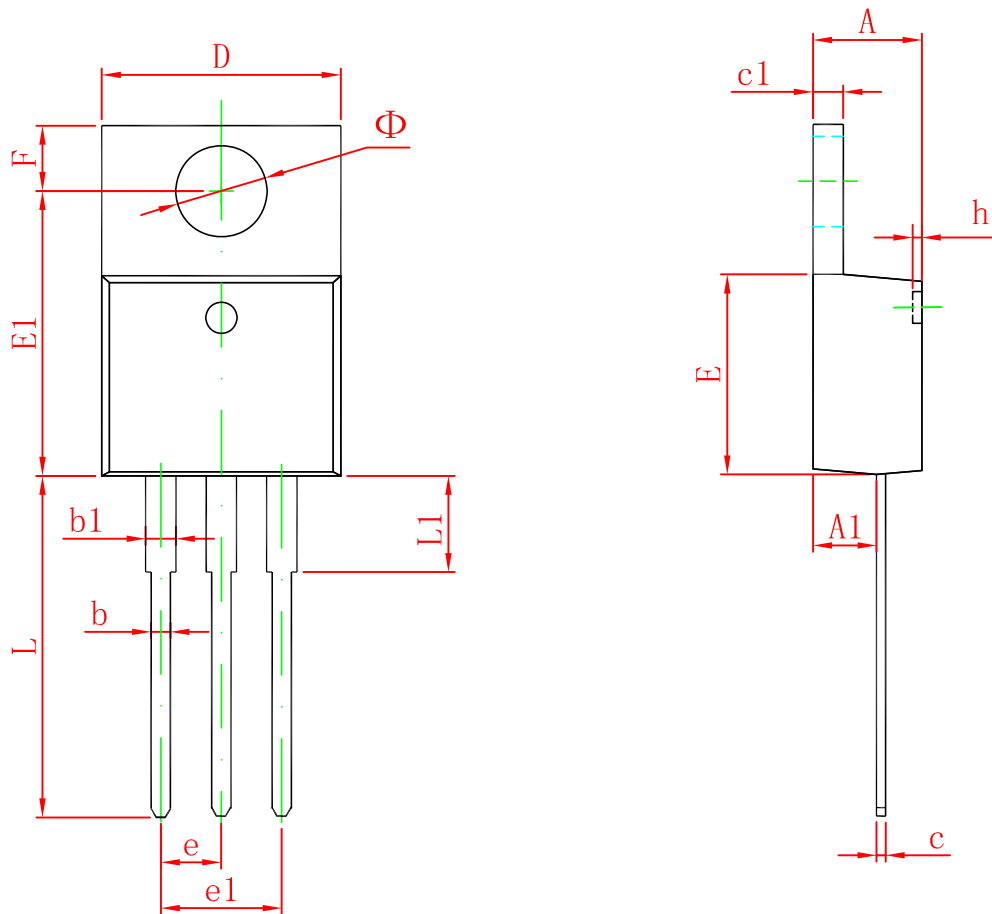

Symbol	Dimensions In Millimeters		Dimensions In Inches	
	Min	Max	Min	Max
A	4.470	4.670	0.176	0.184
A1	2.520	2.820	0.099	0.111
b	0.710	0.910	0.028	0.036
b1	1.170	1.370	0.046	0.054
c	0.310	0.530	0.012	0.021
c1	1.170	1.370	0.046	0.054
D	10.010	10.310	0.394	0.406
E	8.500	8.900	0.335	0.350
E1	12.060	12.460	0.475	0.491
e	2.540 TYP		0.100 TYP	
e1	4.980	5.180	0.196	0.204
F	2.590	2.890	0.102	0.114
h	0.000	0.300	0.000	0.012
L	13.400	13.800	0.528	0.543
L1	3.560	3.960	0.140	0.156
Φ	3.735	3.935	0.147	0.155